

2 BEDROOM 871 SQ.FT. | BALCONY 41 SQ.FT. | TOTAL 912 SQ.FT.

BUILDING B & C

- 302
- 502
- 602
- 702
- 802
- 902
- 1002

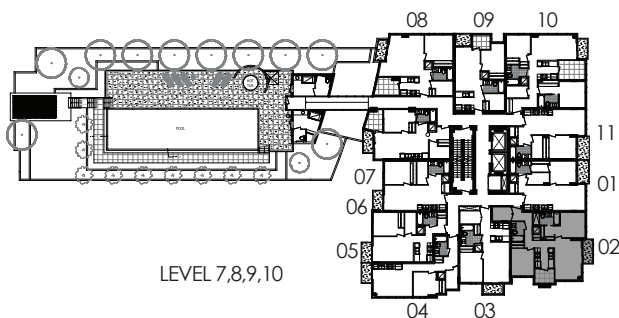
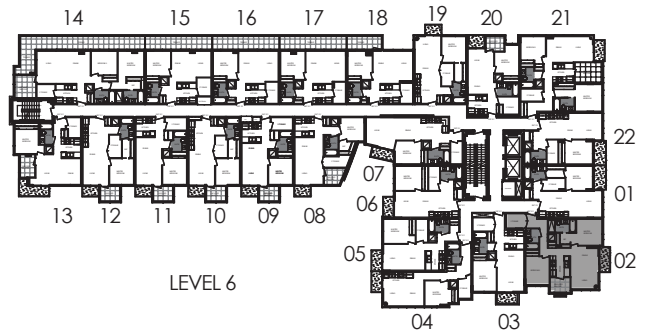
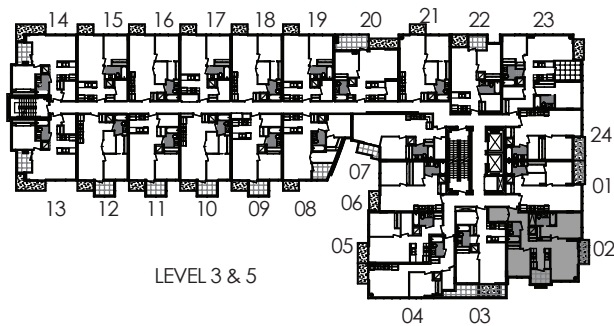

In the interest of product improvement and maintaining high standard of these homes, the developer reserves the right to make modifications and changes to plans, specifications and features. Sizes and dimensions are approximate and may vary with actual strata plan and survey.